

STEEL COLUMN FIRE PROTECTION

TEK 7-6A
Fire Resistance (2009)

Keywords: calculated fire resistance, columns, equivalent thickness, fire resistance ratings, masonry fire protection, steel column fire protection, thermal properties

INTRODUCTION

Because of its inherent fire resistant properties, concrete masonry is often used as a non-structural fire protection covering for structural steel columns. Fire endurance of steel column protection is determined as the period of time for the average

temperature of the steel to exceed 1,000 °F (538 °C), or for the temperature at any measured point to exceed 1,200 °F (649 °C) (ref. 1). These criteria depend on the thermal properties of the column cover and of the steel column (ref. 2). Using this technique, an empirical formula was developed to predict the fire endurance of concrete masonry protected steel columns (refs. 3, 4). This formula is presented in Figure 1, and is also included in the *International Building Code* (ref. 5)

$$R = 0.17(W/D)^{0.7} + [0.285(T_e^{1.6}/K^{0.2})] \times [1.0 + 42.7\{(A_s/d_m T_e)/(0.25p + T_e)\}^{0.8}] \quad (\text{English units})$$

$$R = 1.22(W/D)^{0.7} + [0.0018(T_e^{1.6}/K^{0.2})] \times [1.0 + 384\{(A_s/d_m T_e)/(0.25p + T_e)\}^{0.8}] \quad (\text{SI})$$

where:

A_s = cross-sectional area of the steel column, in.² (mm²)
 d = depth of steel column, diameter of pipe column, in. (mm)
 d_m = density of concrete masonry protection, pcf (kg/m³)
 D = heated perimeter of steel, in. (mm)
 K = thermal conductivity of concrete masonry (see Table 2), Btu/hrft °F (W/mC)

p = inner perimeter of masonry protection, in. (mm)
 R = fire resistance rating of the column assembly, hr.
 t_{web} = thickness of steel column web, in. (mm)
 T_e = equivalent thickness of concrete masonry protection (see Figure 2), in. (mm)
 w = width of steel column, in. (mm)
 W = average weight of the steel column, lb/ft (kg/m)

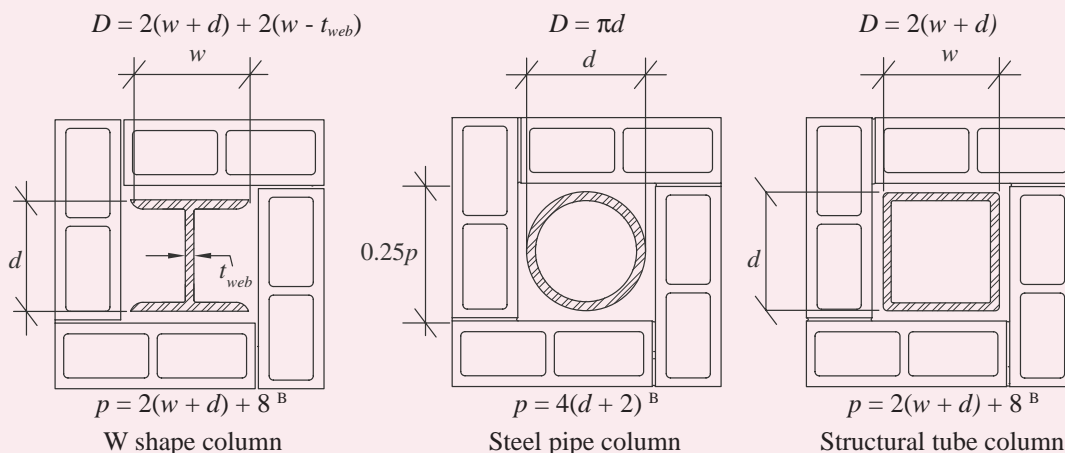

^A Note that *Standard Method for Determining Fire Resistance of Concrete and Masonry Construction Assemblies* (ref. 6) replaces the first term in the above equation with $0.401(A_s/p_s)^{0.7}$ [in SI, $0.042(A_s/p_s)^{0.7}$], where p_s is the same as D above. Both forms of the equation yield identical results.

^B p is calculated based on a 1 in. (25 mm) clearance between the masonry and the steel member. Decreasing this uniform clearance in turn reduces p , which has the net effect of increasing the fire resistance rating for a given equivalent thickness. Using a larger p will require a greater equivalent thickness than shown in Table 1. The masonry may be in contact with the steel element.

Figure 1—Details of Concrete Masonry Protection for Commonly Used Steel Columns (ref. 5)^A

Table 1—Fire Resistance of Concrete

		W SHAPE COLUMNS									
Column size	CM density, pcf	Minimum required T_e for a fire resistance rating, hr, of:				Column size	CM density, pcf	Minimum required T_e for a fire resistance rating, hr, of:			
		1	2	3	4			1	2	3	4
W 14 x 233	85	0.37	0.99	1.61	2.19	W 12 x 50	85	0.95	1.87	2.66	3.36
	105	0.47	1.23	1.94	2.60		105	1.10	2.11	2.95	3.70
	125	0.58	1.46	2.25	2.98		125	1.25	2.33	3.22	4.02
	145	0.70	1.68	2.55	3.34		145	1.39	2.54	3.49	4.32
W 14 x 176	85	0.48	1.20	1.86	2.49	W 12 x 40	85	1.05	1.99	2.79	3.50
	105	0.61	1.44	2.20	2.89		105	1.20	2.22	3.07	3.82
	125	0.74	1.68	2.51	3.26		125	1.35	2.44	3.34	4.13
	145	0.87	1.91	2.81	3.61		145	1.48	2.64	3.59	4.43
W 14 x 120	85	0.66	1.46	2.19	2.85	W 10 x 112	85	0.55	1.32	2.03	2.69
	105	0.80	1.71	2.51	3.23		105	0.69	1.58	2.37	3.09
	125	0.94	1.95	2.81	3.58		125	0.83	1.82	2.68	3.45
	145	1.08	2.18	3.10	3.92		145	0.96	2.04	2.97	3.80
W 14 x 82	85	0.77	1.63	2.39	3.07	W 10 x 88	85	0.67	1.50	2.24	2.91
	105	0.92	1.88	2.70	3.44		105	0.82	1.75	2.56	3.29
	125	1.07	2.11	2.99	3.78		125	0.96	1.99	2.86	3.64
	145	1.21	2.33	3.27	4.10		145	1.10	2.21	3.15	3.98
W 14 x 68	85	0.86	1.76	2.53	3.22	W 10 x 68	85	0.80	1.67	2.44	3.13
	105	1.02	2.00	2.83	3.57		105	0.95	1.92	2.75	3.49
	125	1.17	2.23	3.11	3.90		125	1.10	2.15	3.04	3.83
	145	1.31	2.44	3.38	4.22		145	1.24	2.37	3.32	4.15
W 14 x 53	85	0.95	1.87	2.65	3.36	W 10 x 54	85	0.91	1.82	2.61	3.31
	105	1.11	2.11	2.95	3.69		105	1.07	2.07	2.91	3.65
	125	1.25	2.33	3.22	4.01		125	1.22	2.29	3.18	3.98
	145	1.39	2.54	3.48	4.32		145	1.36	2.50	3.45	4.29
W 14 x 43	85	1.05	1.99	2.78	3.49	W 10 x 45	85	0.96	1.88	2.67	3.38
	105	1.20	2.22	3.06	3.82		105	1.11	2.12	2.96	3.72
	125	1.35	2.43	3.33	4.12		125	1.26	2.34	3.24	4.03
	145	1.48	2.64	3.59	4.42		145	1.40	2.55	3.50	4.34
W 12 x 190	85	0.39	1.04	1.67	2.28	W 10 x 33	85	1.10	2.05	2.86	3.57
	105	0.50	1.28	2.00	2.68		105	1.25	2.28	3.13	3.89
	125	0.61	1.51	2.32	3.06		125	1.40	2.49	3.39	4.19
	145	0.73	1.74	2.62	3.42		145	1.53	2.69	3.64	4.48
W 12 x 136	85	0.53	1.28	1.98	2.62	W 8 x 40	85	0.98	1.92	2.71	3.42
	105	0.66	1.53	2.31	3.02		105	1.14	2.15	3.00	3.76
	125	0.80	1.77	2.62	3.38		125	1.28	2.37	3.27	4.07
	145	0.93	2.00	2.91	3.73		145	1.42	2.58	3.53	4.37
W 12 x 96	85	0.70	1.53	2.27	2.95	W 8 x 31	85	1.10	2.05	2.85	3.57
	105	0.85	1.78	2.59	3.32		05	1.25	2.28	3.13	3.89
	125	0.99	2.02	2.89	3.67		125	1.39	2.49	3.39	4.19
	145	1.13	2.24	3.18	4.00		145	1.53	2.69	3.64	4.48
W 12 x 72	85	0.84	1.73	2.50	3.19	W 8 x 24	85	1.17	2.14	2.95	3.67
	105	1.00	1.97	2.80	3.54		105	1.32	2.36	3.22	3.97
	125	1.15	2.20	3.09	3.87		125	1.46	2.56	3.47	4.27
	145	1.29	2.42	3.36	4.19		145	1.59	2.76	3.72	4.56
W 12 x 58	85	0.91	1.82	2.60	3.30	W 8 x 18	85	1.26	2.25	3.06	3.78
	105	1.07	2.06	2.90	3.65		105	1.41	2.45	3.32	4.07
	125	1.22	2.29	3.18	3.97		125	1.54	2.65	3.56	4.36
	145	1.36	2.50	3.45	4.28		145	1.67	2.84	3.80	4.64

Masonry Protected Steel Columns^{A, B, C}

STRUCTURAL TUBE COLUMNS						STEEL PIPE COLUMNS					
Tube nominal size, in.	CM density, pcf	Minimum required T_e for a fire resistance rating, hr. of:				Pipe nominal size, in.	CM density, pcf	Minimum required T_e for a fire resistance rating, hr. of:			
		1	2	3	4			1	2	3	4
4 x 4 ¹ / ₂ in. wall thickness	85	0.99	1.98	2.81	3.54	4	85	1.29	2.30	3.13	3.86
	105	1.14	2.20	3.08	3.85	Standard	105	1.43	2.50	3.37	4.14
	125	1.28	2.41	3.34	4.15	0.237 in. wall	125	1.56	2.68	3.60	4.41
	145	1.41	2.61	3.59	4.45	thickness	145	1.68	2.87	3.83	4.68
4 x 4 ³ / ₈ in. wall thickness	85	1.10	2.10	2.93	3.66	4	85	1.16	2.16	2.99	3.73
	105	1.25	2.31	3.19	3.96	Extra strong	105	1.30	2.37	3.25	4.02
	125	1.38	2.51	3.44	4.25	0.337 in. wall	125	1.43	2.57	3.49	4.30
	145	1.51	2.71	3.68	4.54	thickness	145	1.56	2.75	3.73	4.58
4 x 4 ¹ / ₄ in. wall thickness	85	1.25	2.25	3.08	3.81	4	85	0.84	1.81	2.64	3.37
	105	1.39	2.46	3.33	4.10	Double extra	105	0.98	2.04	2.92	3.70
	125	1.52	2.65	3.57	4.37	strong	125	1.12	2.26	3.19	4.01
	145	1.65	2.83	3.80	4.65	0.674 in. wall	145	1.25	2.46	3.45	4.31
6 x 6 ¹ / ₂ in. wall thickness	85	0.88	1.83	2.64	3.36	5	85	1.23	2.24	3.06	3.79
	105	1.03	2.06	2.93	3.69	Standard	105	1.38	2.44	3.31	4.07
	125	1.17	2.28	3.20	4.01	0.258 in. wall	125	1.50	2.63	3.55	4.35
	145	1.31	2.49	3.46	4.31	thickness	145	1.63	2.82	3.78	4.63
6 x 6 ³ / ₈ in. wall thickness	85	1.01	1.98	2.79	3.52	5	85	1.08	2.07	2.89	3.62
	105	1.16	2.21	3.07	3.84	Extra strong	105	1.22	2.28	3.16	3.92
	125	1.30	2.41	3.33	4.14	0.375 in. wall	125	1.36	2.49	3.41	4.22
	145	1.44	2.62	3.58	4.43	thickness	145	1.48	2.68	3.65	4.50
6 x 6 ¹ / ₄ in. wall thickness	85	1.18	2.17	2.99	3.71	5	85	0.74	1.68	2.48	3.21
	105	1.32	2.38	3.25	4.01	Double extra	105	0.88	1.91	2.78	3.55
	125	1.46	2.58	3.49	4.30	strong	125	1.01	2.13	3.06	3.87
	145	1.59	2.77	3.73	4.58	0.750 in. wall	145	1.15	2.34	3.32	4.18
8 x 8 ¹ / ₂ in. wall thickness	85	0.83	1.75	2.54	3.25	6	85	1.18	2.17	3.00	3.72
	105	0.98	1.99	2.84	3.60	Standard	105	1.32	2.38	3.25	4.01
	125	1.12	2.21	3.12	3.92	0.280 in. walls	125	1.46	2.58	3.49	4.30
	145	1.26	2.43	3.39	4.23	thickness	145	1.58	2.77	3.73	4.58
8 x 8 ³ / ₈ in. wall thickness	85	0.97	1.92	2.72	3.44	6	85	0.98	1.96	2.77	3.50
	105	1.12	2.15	3.00	3.76	Extra strong	105	1.13	2.18	3.05	3.81
	125	1.26	2.36	3.27	4.07	0.432 in. wall	125	1.27	2.39	3.31	4.12
	145	1.39	2.57	3.53	4.37	thickness	145	1.40	2.59	3.56	4.41
8 x 8 ¹ / ₄ in. wall thickness	85	1.15	2.12	2.93	3.65	6	85	0.63	1.52	2.31	3.02
	105	1.29	2.34	3.20	3.96	Double extra	105	0.77	1.76	2.62	3.38
	125	1.43	2.54	3.45	4.25	strong	125	0.90	1.99	2.91	3.72
	145	1.56	2.73	3.69	4.53	0.864 in. wall	145	1.03	2.20	3.18	4.04
					thickness						

^A in. x 25.4 = mm; CM = concrete masonry; T_e = equivalent thickness of concrete masonry protection (see Figure 2)

^B Equivalent thickness values are based on a calculation of p with a 1 in. (25 mm) clearance between the masonry and steel member (see Figure 1). Decreasing this uniform clearance in turn reduces p , which has the net effect of increasing the fire resistance rating for a given equivalent thickness. Using a larger p will require a greater equivalent thickness than that shown in Table 1 in order to meet a given fire resistance rating.

The masonry may be in contact with the structural steel element, however, consideration should be given to the relative movement. This should be a primary design consideration for structures designed for high lateral loads – such as those from wind or earthquake. Depending upon the design loads and method of masonry support, it may also be necessary to reinforce the masonry providing the fire protection. Such reinforcement may be required prescriptively for seismic design of non-shear wall elements (as a function of the seismic design category) or as necessary to safely resist applied loads.

^C For masonry densities between values listed, T_e may be interpolated, or the next higher density value may be used.

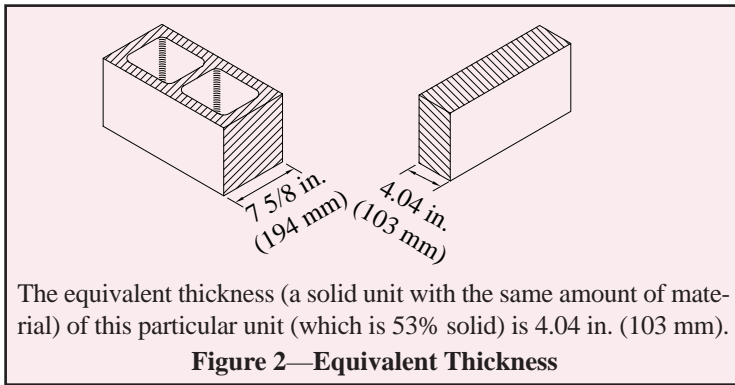

Equivalent Thickness

Equivalent thickness is essentially the solid thickness that would be obtained if the volume of concrete contained in a hollow unit were recast without core holes (see Figure 2). The equivalent thickness is determined in accordance with *Standard Methods of Sampling and Testing Concrete Masonry Units*, ASTM C 140 (ref. 7), and is reported on the C 140 test report. Note that when all cells of hollow unit masonry are filled with an approved material, such as grout and certain loose fill materials, the equivalent thickness of the assembly is the actual thickness. For more detailed information, as well as typical equivalent thicknesses for concrete masonry units, see *Fire Resistance Ratings of Concrete Masonry Assemblies*, TEK 7-1B (ref. 8).

REFERENCES

1. *Standard Test Methods for Fire Tests of Building Construction and Materials*, ASTM E 119-00. ASTM International, 2000.
2. Lie, T. T. and Harmathy, T. Z. *A Numerical Procedure to Calculate the Temperature of Protected Steel Columns Exposed to Fire*, Fire Study No. 28, National Research Council of Canada, March 1972.
3. Harmathy, T. Z. and Blanchard, J. A. C. *Fire Test of a Steel Column of 8-in. H Section, Protected with 4-in. Solid Haydite Blocks*, National Research Council of Canada, February 1962.
4. Lie, T. T. and Harmathy, T. Z. *Fire Endurance of Protected Steel Columns*, ACI Journal, January 1974.
5. *2006 International Building Code*. International Code Council, 2006.
6. *Standard Method for Determining Fire Resistance of Concrete and Masonry Construction Assemblies*, ACI 216.1-07/TMS 0216.1-07. American Concrete Institute and The Masonry Society, 2007.
7. *Standard Test Methods for Sampling and Testing Concrete Masonry Units and Related Units*, ASTM C 140-02a. ASTM International, 2002.
8. *Fire Resistance Ratings of Concrete Masonry Assemblies*, TEK 7-1B. National Concrete Masonry Association, 2008.

Table 2—Thermal Conductivity of Concrete Masonry Units (refs. 4, 5)

Concrete masonry density, pcf (kg/m ³)	Thermal conductivity ^A , K, Btu/hrft ² °F (W/mC)
80 (1,282)	0.207 (0.358)
85 (1,362)	0.228 (0.394)
90 (1,442)	0.252 (0.436)
95 (1,522)	0.278 (0.481)
100 (1,602)	0.308 (0.533)
105 (1,682)	0.340 (0.588)
110 (1,762)	0.376 (0.650)
115 (1,842)	0.416 (0.720)
120 (1,922)	0.459 (0.749)
125 (2,003)	0.508 (0.879)
130 (2,083)	0.561 (0.971)
135 (2,163)	0.620 (1.073)
140 (2,243)	0.685 (1.186)
145 (2,323)	0.758 (1.312)
150 (2,403)	0.837 (1.449)

^A Oven dry thermal conductivity at 70 °F (21 °C)

Provided by:
Midwest Block and Brick, Inc.

NCMA and the companies disseminating this technical information disclaim any and all responsibility and liability for the accuracy and the application of the information contained in this publication.